

DOI: <https://doi.org/10.63332/joph.v5i6.2460>

Enhancing Project Efficiency and Business Overall Performance Through Measuring the Impact of SCM System, Employee Skills, And Project Agility

Mohammed A. Abu Rumman¹, Amer Ahmad Hatamleh², Khaled M.K. Alhyasat³, Rania J. Qutieshat⁴, Ahmad Hanandeh⁵

Abstract

This research aims to study the effects of SCM implementation, Employee skills, and environment agility on project Efficiency and business overall performance. The goal of defining these variables interact is important and critical for competitiveness in unstable environment with a rapid innovative change in technological field. The research chose Zain organization in Jordan in order to conduct this research, a questionnaire of 25 questions has been designed to collect all the needed information about SCM system, employee skills, and environment agility to enhance the project Efficiency and business overall performance. The relationship between the research's variables has been measured based on 171 responses valid for statistical analysis using SEM. The main result of this research summarized that employees should have high technical skills in using SCM system which could be significantly affects enhancing project Efficiency and conduct professionally the business overall performance. Furthermore, this research concluded that apply SCM system is critical to deal with huge amount of data and information, rapid technological change, and rapid changes in job market and turbulent competition.

Keywords: SCM System, Employee Skills, Project Agility, Project Efficiency, Business Overall Performance.

Introduction

SCM systems are essential tools for organizations as an operational and project environment, helping them prepare, adapt, and discover data that is integrated across departments. They represent a sophisticated and significant advance over traditional SCM systems (Hanandeh Et al., 2024). Many companies have focused on implementing technology systems as a means to perform their active operations, improving the efficiency of their processes and methods, and developing them separately (Alam et al., 2024). The application of information technology within organizations has become a key factor in helping organizations increase talent, competitiveness, and achieve the agility and flexibility to deal with the changing work environment. At the same time, organizations have realized that implementing advanced technology systems requires another focus: facilitating and increasing employees' technical

¹ Associate Professor, Business Administration Department, Faculty of Business, Al- Balqa Applied University, Email: aburumman@bau.edu.jo

² Associate Professor, Department of Business Intelligence and Data Analysis, Faculty of Business and Financial Science, Irbid National University, Jordan

³ Associate Professor, HRM Department, Military College, Abu Dhabi University, UAE.

⁴ Associates Professor, Planning and Project Management Department, Business College, Al-Balqa Applied University, Jordan.

⁵ Professor, Business Administration, Faculty of Business, Applied Science Private University, Middle East University, Jordan.



skills to keep pace with technological developments. Learning gives employees the ability to understand how to use advanced technology systems, like SCM system, to increase their capabilities to use them easily (Hammouri Et al., 2024). Companies have realized the value of implementing SCM systems by focusing on developing and training employees' technical capabilities (Mansour et al., 2024). Organizations understand that improving the quality of the collaboration process and increasing operational effectiveness and efficiency requires highly skilled employees who can effectively perform the Newton system's processes. This enables them to quickly and creatively solve problems, which directly impacts overall performance, increases project Efficiency, and enables control over high-quality data. Organizations have also focused on increasing the project environment flexibility which significantly impact the growth and benefits of using SCM systems (Smith, 2024; Claro et al., 2024). This includes the need to deploy updates quickly, adjust them appropriately, and adapt project processes and system functions to the changing organization. Organizations understood that project flexibility support in building innovative environment with an added value qualities and suitable cost, solving issues and problems, and being proactive for meeting risks. Focusing on these three variables has become important for organizations which aims to enhance performance skills and improve productivity (Budiarto et al., 2024; Orakova et al., 2024). Applying advanced technology like SCM system is important for organizations to improve the efficiency of organization operations. although the importance of applying SCM system, enhancing employees skills, and increase project flexibility considered important for doing daily and operation tasks and impacts positively vin overall performance and for that there are still lake in researches which focused on researching the impact of three variables together which required more studies and analysis. Organizations understood the difficulty to work in unstable environment with rapid change in technological and environment fields and need to weekly training for their employees in order to face and meet competitor's daily operation tasks are considered very important for maintaining their market positions. This research focuses on closing the scientific gap through researching and exploring the impact of applying SCM system, enhancing employee skills, and building and creating innovative and stable flexible project and measuring all there dimensions impacts on improve project Efficiency and business overall performances.

Literature Review

Supply Chain Management (SCM)

SCM software is known as an integrated software which used to save and collect all the needed data and information in save them all in online server, then retrieve them during performing daily operational tasks (Bozorova et al., 2024; Chiu & Sanusi, 2024). Now, most of organizations started to give responses for the huge amount and changes which occur in market environment with other competitors which require fast decisions to deal with sudden issues and risks (Alam et al., 2024). Collecting and saving all the needed data and information through using online server helps organizations to a carry out more transactions, decreasing costs, enhance products quality (MANDAVA, 2024; Masenya & Aroba, 2025). SCM system leads organizations to make unique decisions based on saved data and enhance organization agility, and encourage applying advanced technological solutions in order to deal with market unstable changes (Al-Quraishi et al., 2024; Smith, 2024; Manigandan & Raghuram, 2024). SCM system can give organizations a lot of advantages like producing ideal unified data form based in the integration of all retrieved data from organizations departments, and save them in online server, and helps decision makers for retrieve data and use them easily (Gooda et al., 2025). Saving all data in unified database helps organization to read all data in good and new way which increase the percentages of

discovering new communications and relations that increase the ability for innovation and creativity, proposing new solutions. Create long term strategic plan, and developing overall performance. also, applying advanced technology like SCM system can help organization to enhance predictive analysis processing and daily reports, which also with impact on operational level tasks and best managing organizations resources. SCM systems enable organizations to integrate and utilize data from multiple departments and divisions to meet the organization's overall objectives, gain greater competitive advantages, and manage any change or development within a highly professional work environment. Currently, with most organizations adopting technological solutions to perform business and reaching the stage of digital transformation, supply chain management systems have become the key to success that organizations rely on to support long-term strategic goals and promote sustainable business growth. They have become an important and decisive factor in enhancing project Efficiency, improving the quality of business overall performance, and enhancing project flexibility.

Employee Skills

Improving employee skills and increasing their efficiency is seen as increasing the effectiveness of employees within organizations in using technical and digital tools and systems to achieve operational goals and leverage startup benefits. Technology solutions, like the implementation of SCM systems, are key to success and pillars for those government organizations that decide to rely on comprehensive, well-studied data from all departments to build advanced systems. Technology cannot be utilized without a workforce capable of advanced leveraging these systems (Gökçearsan et al., 2024). Many organizations face significant challenges at the hands of technological advancements, forcing them to offer training courses to their large teams to improve their skills and knowledge on how to handle and operate these systems advanced (Groenewald et al., 2024). The added value within organizations and the implementation plans to improve overall performance now depend on technological advancements and the capabilities and knowledge of employees to provide new ideas (Cui, 2024). Given the fast-paced work environment of a large sector, like the logistics sector, employees are required to quickly learn and adapt to the use of any new technological system. This is due to the lack of time management to stop operational processes. Organizations are now looking to hire administrative staff to respond quickly to challenges, reduce necessary errors, and accelerate production processes in a thoughtful and professional manner. It also improves employee skills, one of the main monthly necessities, regarding data accuracy and integrity, in addition to fully operating a organization management system to use it in a way that connects organizations and achieves their work and goals, increasing their efficiency and enabling them to compete in the necessary labor market (Atobishi et al., 2024; Fachridian et al., 2024). Employee skills and efficiency do not depend on enhancing only the technical skills, but also include employee registration. Conversely, these skills are essential for achieving the organization's advanced goals and plans and increasing overall performance. Therefore, training programs and workshops must come from within organizations, focusing on the required elements first and foremost. This is essential to provide employees with organized skills and increase their ability to use SCM systems more generally. The use of this system relies on monitoring employees' ability to SCM stored data and link it to achieving objectives according to the plan. Employees' preparation, skills, and talents must be able to handle complex operations and tasks, and rapid and thoughtful subscriptions based on changing data within the market, regulated for a flexible project with the natural changes of competition within the market. Finally, this provides employees with sufficient efficiency and the ability to use the system correctly and detect any errors when they occur, ensuring the

suitability of SCM systems for performing work. However, the organization's SCM systems are limited and unsuitable for optimal use of resources and overall system performance at its three levels: operational, administrative, and executive (Ononiwu et al., 2024).

Project Agility

Project agility is defined within organizations as their ability to quickly adapt to any internal or external change occurring in a turbulent and changing labor market and massive technological developments in a flexible, advanced, interactive, or proactive manner. This approach aims to achieve sustainability, maintain overall performance, exploit any available opportunity, mitigate any threat, or resolve any potential problem when it arises (Motwani & Katatria, 2024). Increasing project agility within organizations at all levels, particularly flexibility in interactions between employees and managers at various levels, has become a key and important factor, allowing organizations to maintain competitiveness and create a work environment that can quickly adapt to any change as it occurs (Fachridian et al., 2024). Project agility gives organizations the ability to revisit and modify resource usage methods, alter strategies, and improve operations according to required changes. This ensures that any decision made is based on up-to-date, processed, and stored data and information in a single location and using an advanced technological system, like a SCM system. Project flexibility also gives organizations the ability to quickly and flexibly initiate work, creating and increasing levels of creativity and innovation, which are among the most important characteristics for achieving sustainable success in this era (Groenewald et al., 2024). This characteristic gives organizations the ability to create and build a culture that helps employees learn, correct mistakes, and respond to any change in job performance across any department within the organization. Project flexibility is based on laws related to increasing the rates of adaptation and responsiveness, creating work teams, continuous learning, and decentralized business overall performance. These components, pillars, or elements are among the tools organizations need to transform traditional administrative structures into flat, digital structures that rely on collective business overall performance, empower employees, and grant them more authority (Cui, 2024). They also help organizations reduce volatility and change within the organization, create more strategic initiatives, increase internal coordination, improve communication methods, and enhance and develop the alignment between strategic plans and operational processes. Finally, organizations that have adopted the concept of increasing project traffic have proven their ability to manage risks, increase customer satisfaction, and seize available opportunities within the market, becoming one of the most important elements for achieving sustainable performance, possessing competitive advantages, and creating an advanced project environment that relies on the use of technological systems and good social interaction between management and employees as a single unit to confront any risk, solve any problem, exploit any opportunity, create new ideas and values, increase customer satisfaction, and add innovative competitive values to the final products provided to customers (Atobishi et al., 2024).

Project Efficiency

Most projects focus on increasing their operational capabilities and efficiency as the most important pillars that ensure optimal use of project resources, reduce waste, and improve productivity while maintaining global quality standards and enhancing overall performance. Project Efficiency refers to a project's ability to deliver finished products in an efficient manner, while improving quality and reducing costs, which enhances its competitive advantage (Khan et al., 2024). The need to develop project Efficiency has emerged as a natural response to increased

competition, rising operating costs, and increasing complexity within the work environment (Tian et al., 2024). Furthermore, the introduction of advanced technological systems like enterprise resource management systems (ERMs) has led projects to need to enhance employee skills and improve operational efficiencies in an effort to address and simplify workflows, reduce workflow steps, automate processes, reduce duplication, and increase response time. Today, competition among projects is based on providing distinctive, high-quality value at a low cost and with remarkable speed. Customers' most important demand is for projects to respond quickly to their requests. Without increasing project Efficiency, it becomes difficult for projects to respond quickly to customer requests. This feature has given projects the ability to increase production rates at lower costs, reduce operational errors and delays in delivering orders to customers, and enhance the project's overall performance (Petchrompo et al., 2025). Operational skills and efficiency depend on several columns, for example successful enhancing employee skills, developing processes, and continuously monitoring overall performance using global standards (Nguyen et al., 2025). Project Efficiency is based on a single quality standards and rules in controlling all executed tasks within project. Through this approach to work performance, projects have empowered their employees to increase the percentage of correct work performance and improve the internal work environment. This ultimately impacts customer satisfaction with the services provided, which have new specifications, free of errors, at the same costs and with better quality. Project Efficiency processes have become the primary source for strategic management in developing strategic plans, supported by accurate data reflecting customer feedback. They have provided projects with sufficient methods to optimally utilize resources, deliver the best services and products, and perform operations quickly and innovatively, making them a key element in achieving strategic objectives and possessing competitive advantages (Khan et al., 2024). Finally, having high project Efficiency gives projects the ability to increase their competitive advantage, improve their economy, increase sustainability, reduce costs, and build long-term relationships with stakeholders, including suppliers and distributors.

Business Overall Performance

Business overall performance is considered the most important element within organizations because it impacts all levels of the organization. It is considered the true and primary reason for an organization's success or exit from the competitive market, as it impacts all strategic, operational, and administrative levels, impacting overall performance and the organization's long-term success rates. It reflects the success of strategic plans, the ability to cope with change, seize and exploit any available opportunities, and confront the risks that organizations may face (Singh et al., 2024). At this time, the business overall performance process is considered one of the steps that must be performed quickly and based on data, not just the manager's opinion. It must be aligned with the organization's objectives and reflect long-term values and visions (Baabdullah, 2024). The business overall performance process contributes to building a culture that encourages the promotion of standards and concepts like transparency, accountability, accurate evaluation of situations, comparison of alternatives, and optimal selection based on the nature of the work, facing challenges, and optimal exploitation of any available strategic opportunities (Virmani et al., 2024). Data-driven business overall performance, powered by tools, analytics, and digital systems like SCM systems, will support cross-departmental collaboration and help make business overall performance more collaborative and market-driven (Egerson et al., 2024). Several factors influence the quality of business overall performance, including the availability of up-to-date, reliable, and accurate information, the skills and

competence of the decision-maker, and the presence of project processes and operational competencies capable of making objective, data-driven decisions. In addition, this era of massive technological advancements and complex environmental changes is a time that supports building a culture that encourages respect for different viewpoints and gives everyone a role in business overall performance based on stored data retrieved from modern technologies like decision support systems and business intelligence systems, which play a pivotal role in processing complex data and giving business overall performance the ability to read all data digitally (Sahin et al., 2024). This makes the business overall performance process a proven process without a doubt, increasing project and customer satisfaction with the new competitive advantages. Business overall performance, based on technology and the possession of talented employees, becomes an integrated process that leads the organization to success at all levels and makes the organization's environment one that supports innovation, flexibility, and continuous improvement to face challenges and work complexity and solve problems to achieve long-term sustainability (Sembiring et al., 2024).

The following research proposals are derived from prior investigations and analysis, and they are as follows:

- H1: SCM system have a strong and positive impact on improving project Efficiency.
- H2: SCM system have a strong and positive impact on enhancing business overall performance.
- H3: Employee skills has a strong and positive impact on improving project Efficiency.
- H4: Employee skills has a strong and positive impact on enhancing business overall performance.
- H5: Project agility has a strong and positive impact on improving project Efficiency.
- H6: Project agility has a strong and positive impact on enhancing business overall performance.

Fig. 1 shows the structure of the proposed research.

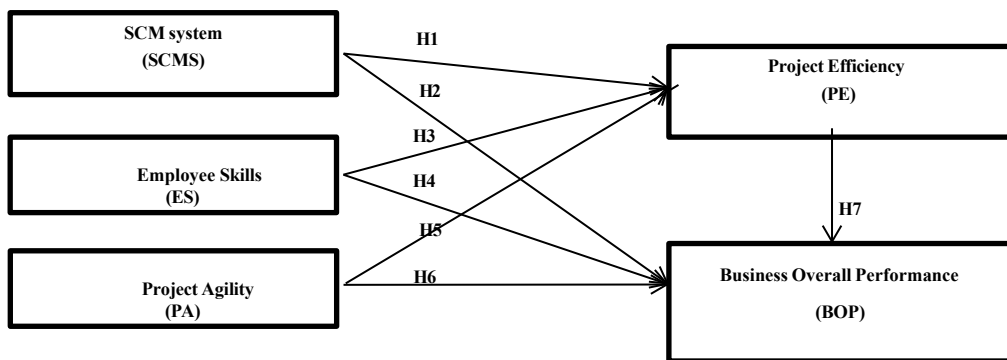

Fig. 1. Research Model

Research Methodology

This research carried out this research in Zain Organization in order to determine and define the main impacts of applying advanced technology like SCM system, improve employee's skills,

and increase project flexibility on improving project Efficiency, and business overall performance quality. This research designed and used research survey consists of 25 main questions which used to measure the impacts of independent variables on dependent variables. 171 valid questionnaires were collected from main departments like IT department, HR department, and manufacturing department and all respondents were chosen based on knowledge and experience and the total understanding for main processes and technology which used within the organization. The research survey used advanced and accurate statistical tools and techniques in order to analyze all collected data arrived to get results which used in discussing research hypotheses. The research results reached the following: organizations which applied SCM system solved a lot of issues related with business overall performance, the implementation of advanced technology like SCM system supports organization to enhance employee skills and capabilities, and it helps also in create flexible project encourages employees to work hard which affects eventually on improving operation efficiency, improve products specifications, and overall performance.

Research Design

The research questionnaire was wisely planned and disseminated digitally in orientation with the research goals. It consisted of five main parts containing a total of 25 questions, each aiming on the core variables of the research. These involved the independent variables SCM system, employee's skills, and project flexibility on top of the dependent variables operational effectiveness and business overall performance. The creation of the survey was considered for taking participants' explanations, experiences, and duties related to the use of SCM systems and project practices at Zain. To certify reliable data collection and enquiry, a five-point Likert scale was used through all questions, allowing respondents to rapid their level of arrangement from "strongly disagree" to "strongly agree." This measure enabled nuanced answers that give back the extent of influence each variable had within the organization.

The collected data were valued using SMART PLS 3.3.9 to test the planned theoretical model and research hypotheses. This structured and analytical approach basic the proof of identity of significant relationships between the independent and dependent variables, so long as all-inclusive accepting of how digital tools and project skills interact to enrich performance. The results following from the survey offer valued comprehensions for organizations for the most part Zain targeting to growth internal effectiveness and business overall performance. These results can funding strategic planning determinations and back to the optimization of things and the advance of agile, data-driven project opinions.

Research Analysis

The SMARTPLS-SEM 3.3 system was subjugated to transform the collected data into analyzable and meaningful insights that could effectively examination the research's proposed hypotheses. Prior to analysis, all data were carefully entered and screened to ensure accurateness and to address any potential data entry errors. Each response was reviewed for completeness, correctness, and consistency to maintain the reliability of the research results. The analysis focused initially on evaluating the capacity model, assessing the reliability and validity of the constructs through composite reliability, average variance extracted (AVE), and factor loadings. Two primary steps of analysis were employed: the first involved considering the measurement model to confirm convergent and discriminant validity, and the second evaluated the structural model to assessment the hypothesized relationships amongst the variables.

SPSS was also in employment during the initial data screening phase to confirm the accuracy and suitability of the dataset. Mahalanobis distance analysis was focused to detect and address major outliers, confirming the strength of the final dataset. A Chi-square (χ^2) test was charity to study goodness-of-fit, with significance levels continued below 0.001 to indorse the strength and consistency of the model. The threshold χ^2 value was well-known at 14.36, and observations exceeding this value were added studied. After data cleaning, a total of 171 valid questionnaires were engaged for final analysis. The data giving out was experienced for regularity, with skewness and kurtosis values falling within the suitable range of ± 2 , signifying no thoughtful deviations from normality.

The assessment of the research model resulted by assessing the measurement model surveyed by the structural model. Confirmatory factor analysis (CFA) was directed to validate the four main theories of the study, using Bonferroni adjustments to control for Type I errors. The model confirmed strong internal consistency and reliability, supporting the theoretical framework. The combination of robust statistical measures and a well-grounded theoretical approach confirmed the validity and reliability of the research decisions, contributing valuable conceptions into project performance at Zain.

Measurement Model Assessment

This research in employment a structured questionnaire concerning of 25 questions that embattled five main mechanisms ranged with the studies independent and dependent variables: SCM systems, employee skills, project agility, operational proficiency, and business overall performance. Before guiding the theoretical investigation, the reliability and validity of the measurement model were evaluated to confirm the robustness of the research basis. The consistency and reliability of the items were stately by evaluating the outer (external) loadings of each sign on its corresponding hypothesis. High outer loadings showing a strong correlation between each element and its particular latent variable, approving the internal consistency of the constructs and successful the overall reliability of the research model (Hair et al., 2021). This methodological style as long as a constant basis for the structural model assessment and comprehensive that all concepts accurately represented their theoretical thoughts. The thorough examination of measurement accuracy and item regularity strengthened the validity of the research's results and maintained significant int SCMretations of the relations between the studied variables.

Variable	Factor's Loading	VIF	Cronbach's Alpha	CR	AVE
SCM system (SCMS)			0.50	0.52	0.60
System integration	0.66	0.44			
Data accessibility	0.50	0.54			
Real-time reporting	0.65	0.60			
System reliability	0.60	0.54			
User satisfaction with SCM	0.65	0.66			
Employee Skills (ES)			0.54	0.53	0.63
Technical skills	0.65	0.40			
SCM usage experience	0.50	0.46			
Training level	0.66	0.50			
Problem-solving ability	0.54	0.46			
Adaptability to new systems	0.65	0.56			

Project Agility (PA)			0.50	0.54	0.62
Speed of response to market changes	0.50	0.35			
Flexibility in resource allocation	0.65	0.42			
Ability to implement process changes	0.60	0.55			
Cross-functional collaboration	0.66	0.36			
Scalability of operations	0.69	0.43			
Project Efficiency (PE)			0.56	0.50	0.60
Process automation	0.63	0.43			
Cycle time reduction	0.65	0.55			
Resource utilization	0.64	0.54			
Cost reduction	0.66	0.64			
Error rate in operations	0.56	0.53			
Business overall performance (DMQ)			0.53	0.50	0.59
Accuracy of decisions	0.65	0.44			
Timeliness of decisions	0.50	0.45			
Use of data analytics	0.66	0.52			
Clarity of decision outcomes	0.53	0.66			
Consistency in business overall performance	0.62	0.65			

Table 1. Reliability and Validity Test

Convergent validity was measured in this research by exploratory two key statistical indicators: the Average Variance Extracted (AVE) and Composite Reliability (CR). The AVE standards for each construct overdone the threshold of 0.50, representing that more than half of the variance experimental in the indicators is described by their conforming latent construct. This authorizes that the constructs share a high degree of modification with their measured items, which funds convergent validity (Hair et al., 2021). Composite Reliability (CR) was also calculated to value the internal consistency of the constructs, with all CR values greater than the mentioned minimum of 0.70, demonstrating reliable measurement consistency. These procedures are essential for verifying that the items used to represent the latent variables SCM systems, employee skills, project agility, project Efficiency, and business overall performance value are statistically thorough and theoretically valid. Organized, the AVE and CR values established that the displays are appropriately gathered and reflect the intended constructs, so strengthening the reliability and validity of the measurement model used in this study.

Research Hypotheses Test

The second phase of the study, following the confirmation of reliability and validity of the research model, complex testing the research's hypotheses to value the relationships between the independent and dependent variables. This phase motivated on evaluating how the core independent features SCM systems, employee skills, and project agility straight influence the dependent variables, namely project Efficiency and business overall performance. The following table grants the results of the structural model, emphasizing the direct impacts and statistical implication of all hypothesized relationships approved in the research.

	Research Hypotheses Test	P Value	Results
H1	SCM system (SCMS) → Project Efficiency (PE)	0.000	Supported
H2	SCM system (SCMS) → Business overall performance (DMQ)	0.002	Supported
H3	Employee Skills (ES) → Project Efficiency (PE)	0.000	Supported
H4	Employee Skills (ES) → Business overall performance (DMQ)	0.000	Supported
H5	Project agility (PA) → Project Efficiency (PE)	0.000	Supported
H6	Project agility (PA) → Business overall performance (DMQ)	0.002	Supported
H7	Project Efficiency (PE) → Business overall performance (DMQ)	0.001	Supported

Table 2: Path Coefficient Test Results

The figure expressions the PLS-SEM Analysis results, the SCM system theory was by five indicators with factor loadings going from 0.25 to 0.37. This value shows a moderate level of reliability where 0.61 is connected to evidence-based strategies which are the strongest contributors and play a significant but not comprehensive role in influencing project Efficiency and business overall performance. The figure spectacles the PLS-SEM Analysis results, the employee skills construct was embodied by five indicators with factor loadings ranging from 0.25 to 0.48. This value shows a moderate level of reliability where 0.63 is related to evidence based strategies which are the strongest providers and play a major but not comprehensive role in prompting project Efficiency and business overall performance. The figure displays the PLS-SEM Analysis outcomes, the project agility construct was signified by five indicators with factor loadings ranging from 0.26 to 0.46. This value shows a moderate level of reliability where 0.62 is related to evidence-based strategies which are the strongest providers and play a major but not comprehensive role in talk into project Efficiency and business overall performance. The results also exposed that successful project Efficiency and business overall performance is statistically important as presented by the probability values for example (0.002, 0.001, 0.001, 0.002, 0.001, 0.001 and 0.001). These results show that SCM system, employee skills, and project agility together contribute to progress project Efficiency and business overall performance. The results expression that third independent variable the project agility have a more significant impact based on its strong loading factors. Each of the independent variables show business a prominent and fully associated role in successful the dependent variables, and the effort on them is emphasized as influential factors in accomplishing project quality.

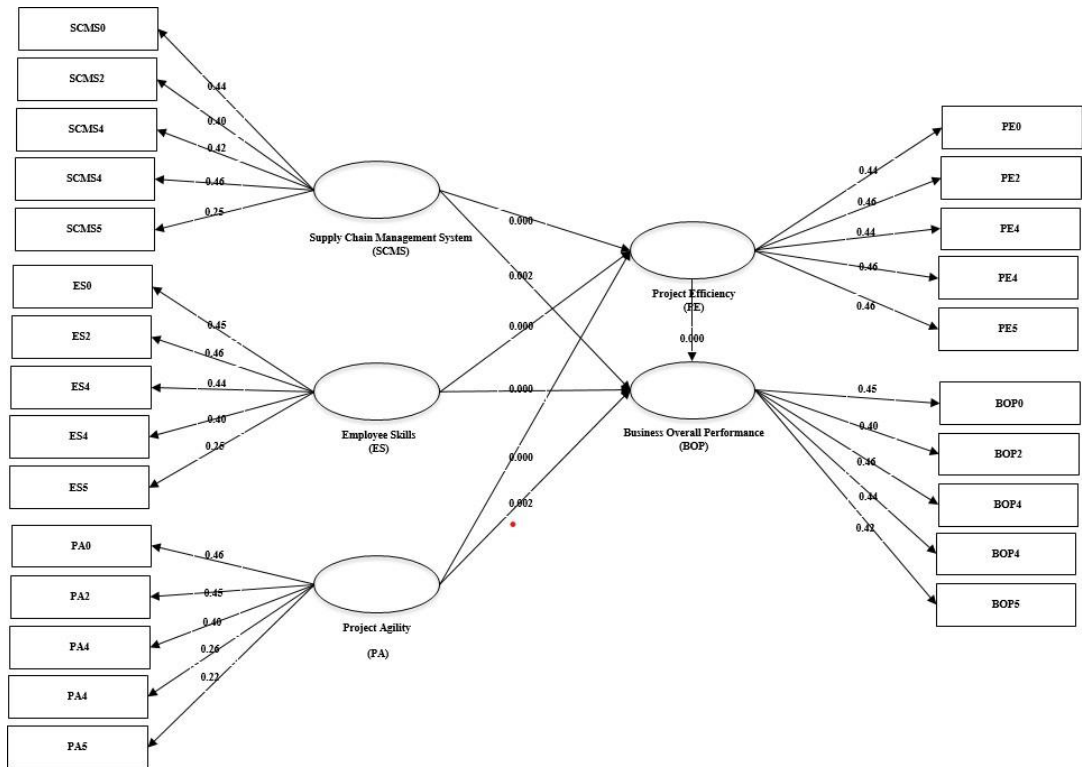

Fig.0. PLS-SEM Path Analysis Result

Research Discussions

The research was presented at Zain in Jordan, focusing on the impact of SCM system, employee skills, and managerial agility on project Efficiency and business overall performance. As Zain operates in a highly dynamic and competitive business environment, it is essential for the organization to recognize how these key influences give to keeping agility, optimizing operations, and improving strategic business overall performance. In the face of rapid technological enhancements and digital transformation, organizations like Zain must approve integrated systems and approve that employees keep the required skills and adaptability to exploit these systems successfully. The primary objective of this research is to estimate how the operation of a SCM system, along with high employee skills and project agility, can increase internal procedures, increase efficiency, and improve the quality of decisions made at various managerial steps. SCM systems transaction real-time access to business data, empowering timely and informed business overall performance, while employee skills approves that these systems are utilized to their full likely. Meanwhile, project agility agrees the organization to return rapidly to changes, make straight its assets with market demands, and sustain show. The outcomes of the research specify that the synergy between these three variables significantly gives for successful project Efficiency and improving business overall performance. SCM systems update workflows and advance data correctness, employee skills ensures effective system utilization, and project agility helps responsiveness and innovation. Together, these essentials care a more adaptive, data-driven, and competitive business situation. Furthermore, the research commends that Zain can develop performance displays like process cycle times,

decision reliability, employee adaptability, and system employment rates to evaluate and track progresses in operational and strategic completions. These metrics can have the funds for insights into how effectively the organization is leveraging technology and human capabilities to chance its goals. The outcomes and recommendations of this research will be common with Zain management and business overall performance, proposing evidence-based management for improving their SCM strategies and workforce development initiatives. Ultimately, embracing SCM systems, cultivating employee skill, and adopting project agility can point Zain for sustainable growth, competitive advantage, and long-term achievement in the Jordanian business institution.

Research Limitations

The research in the field of digital transformation has resolute on the impacts of data-driven business overall performance, real-time data study, and data makes on human resource management and employee accomplishment, like studies displayed within Jordanian Zain Company. Instead, the generalizability of those results may be partial due to the exclusive operational position, project opinions, and improvement strategies specific to the industrial sector. This research is applied within Zain, an organization operating in a different industry with diverse structural, cultural, and strategic features. These variances influence employee expectations, technological adoption, and project responses, making it crucial to check and reevaluate such variables within the specific context of manufacturing and business group operations. Also, the fast marched evolution of technologies like SCM systems and the current shifts in workforce dynamics and project priorities impose continuous and updated evaluations to confirm the relevance and accuracy of research results. The research also concedes certain limitations common in research survey, like social attraction bias and respondent variability, which may move the accuracy and independence of the data collected. Despite these limitations, the research ensures the reliability and legitimacy of its measures and inspires future researchers and practitioners to build upon its methodology by further refining data gathering tools and become accustomed them to changing project contexts. Moreover, the results submit the basic for future research to explore the external environment, including market environments, regulatory shifts, and technological trends, as these external aspects also significantly influence project Efficiency and business overall performance. Internal fundamentals like executive manager's way, digital skills, and project agility must be considered alongside outdoor variables to change a comprehensive and integrated understanding of how modern enterprises can augment operations and complete sustainable strategic outcomes. In conclusion, while this research provides valuable perceptions into the part of SCM systems, employee skills, and project agility at Zain, it also give emphasis to the significance of context in research. A broader, sector-spanning approach is required to method a robust knowledge base that updates the practical application of SCM technologies and structural transformation across manufacturing.

Research Conclusions

This research discovered the impression of SCM systems, employee skills, and project agility on improving project Efficiency and successful the quality of business overall performance at Jordanian Zain company. The research suggested seven hypotheses: Hypotheses H1, H3, and H5 motivated on assessing the influence of the three independent variables (SCM systems, employee skills, and project agility) on project Efficiency. Hypotheses H2, H4, and H6 studied the impact of the same variables on business overall performance. The seventh hypothesis (H7) discovered the relationship between project Efficiency and its impact to business overall

performance, providing a mediating perspective on how operational improvements explain into better strategic outcomes. The primary aim of this research is to clarify how leveraging advanced technologies, development employee capabilities, and developing agile project structures can drive continuous enhancement in both operational and strategic dimensions. By analyzing this interaction, the research seeks to suggest a deeper understanding of how these elements collectively support performance optimization in complex, fast exchanging business environments like that of Zain. The results are particularly valuable for Zain as it directs an increasingly competitive and technology-driven market. By only if actionable intuitions and practical approvals, the research chains the organization's efforts to sustain a competitive edge, enhancement business overall performance effectiveness, and streamline actions.

The results are also maintained by recent studies like those by Olawale et al. (2024), Okatta et al. (2024), and Alabi et al. (2024), which highlight the significance of digital transformation and human factors in driving project performance. Additionally, this research contributes to the growing body of literature that links digital capability and agility to improved business outcomes. While many similar studies have been showed in public or manufacturing sectors, this research offers new insights from the context of a varied business group operating in Jordan, potentially informing strategies in other activities and settings as well. Finally, the research make even with and builds upon previous works by Di Prima et al. (2024), Mateen et al. (2024), and Alabi et al. (2024), which approve the importance of integrating advanced technologies and human competencies to promote project efficiency and business overall performance. As organizations face constant technological interruption and increasing market pressures, this research provides a strategic vision for sustaining high performance and agile responses in rapidly evolving business environments. This research is also supported by studies like Barcak (2024), who explored SCM solutions for small and medium businesses, Gooda et al. (2025), who argued scalable supply chain management systems and implementation strategies, and Masenya and Aroba (2025), who analyzed the employment of SCM systems in the South African mining industry. Manigandan and Raghuram (2024) addressed the role of SCM adoption in improving entrepreneurial orientation and marketing performance in SMEs, while Smith (2024) focused on the impact of SCM systems on supply chain management. The work by Claro et al. (2024) on digital competences further supports the idea that employee skills is crucial in leveraging technology for project Efficiency. Additionally, Budiarto et al. (2024) analyzed the impact of human resource competencies on performance, providing further evidence of the role of competencies in project success.

References

- Alam, M. J., Sharma, S. D., & Chowdhury, T. (2024). A Model of Supply chain management (SCM) for Small and Medium Ent SCMrise. *Journal of Computer and Communications*, 12(10), 37-50.
- Al-Dwairi, R., Shehabat, I., Zahrawi, A., & Hammouri, Q. (2024). Building customer trust, loyalty, and satisfaction: The power of social media in e-commerce environments. *International Journal of Data and Network Science*, 8(3), 1883-1894.
- Al-Quraishi, T., Mahdi, O. A., Abusalem, A., NG, C. K., Gyasi, A., Al-Boridi, O., & Al-Quraishi, N. (2024). Transforming Amazon's Operations: Leveraging Oracle SCM with Advanced Analytics for Data-Driven Success. *Applied Data Science and Analysis*, 2024, 108-120.
- Al-Zagheer, H., AlDa'jah, A. K., Hammouri, Q., & AlShawabkeh, H. A. (2024, February). The Role of Internal Knowledge Management Capabilities with the Internet of Things. In *2024 2nd International Conference on Cyber Resilience (ICCR)* (pp. 1-5). IEEE.
- Atienza-Barba, M., del Río, M. D. L. C., Meseguer-Martínez, Á., & Barba-Sánchez, V. (2024). Artificial

- intelligence and project agility: An analysis of scientific production and future trends. *European Research on Management and Business Economics*, 30(2), 100253.
- Atobishi, T., Moh'd Abu Bakir, S., & Nosratabadi, S. (2024). How do digital capabilities affect project performance in the public sector? The mediating role of the project agility. *Administrative Sciences*, 14(2), 37.
- Baabdullah, A. M. (2024). The precursors of AI adoption in business: Towards an efficient business overall performance and functional performance. *International Journal of Information Management*, 75, 102745.
- Barcak, T. (2024). SCM solutions for small and medium businesses. In 9th International Scientific Conference on Business Administration Abstract and Proceeding Book (No. 182, p. 50).
- Bozorova, G. M., Mamatov, R. R., Adaxamjonov, A. A., & Jaloldinov, M. S. (2024). The Use Of Information Technology In The Formation Of Professional Competence Of Foreign Language Teachers. *Science and innovation*, 3(Special Issue 19), 352-354.
- Braik, M., Al-Hiary, H., Alzoubi, H., Hammouri, A., Azmi Al-Betar, M., & Awadallah, M. A. (2025). Tornado optimizer with Coriolis force: a novel bio-inspired meta-heuristic algorithm for solving engineering problems. *Artificial Intelligence Review*, 58(4), 1-99.
- Budiarto, B. W., Karyadi, S., Judijanto, L., & Febrian, W. D. (2024). Analysis Of The Influence Of Spiritual Capital, Motivation And Work Competencies On Performance Of Human Resource In Smes Sector. *JEMSI (Jurnal Ekonomi, Manajemen, Dan Akuntansi)*, 10(1), 240-246.
- Chiu, T. K., & Sanusi, I. T. (2024). Define, foster, and assess student and teacher AI literacy and skills for all: Current status and future research direction. *Computers and Education Open*, 100182.
- Claro, M., Castro-Grau, C., Ochoa, J. M., Hinostroza, J. E., & Cabello, P. (2024). Systematic review of quantitative research on digital competences of in-service school teachers. *Computers & Education*, 105030.
- Cui, J. (2024). Does digital strategy, project agility, digital leadership promote DT? A research of digital strategy, organizational agility, digital leadership affects corporate DT in Chinese technological firms. *Journal of Integrated Social Sciences and Humanities*.
- Egerson, J. I., Williams, M., Aribigbola, A., Okafor, M., & Olaleye, A. (2024). Cybersecurity strategies for protecting big data in business intelligence systems: Implication for project Efficiency and profitability. *World J. Adv. Res. Rev*, 23, 916-924.
- Fachridian, A., Ramli, A. H., & de Araujo, L. M. (2024). Implementation of project agility strategies to meet the challenges of digital transformation in government organizations. *Media Ekonomi Dan Manajemen*, 39(2), 215-233.
- Gökçearsan, Ş., Yildiz Durak, H., & Atman Uslu, N. (2024). Acceptance of educational use of the Internet of Things (IoT) in the context of individual innovativeness and ICT skills of pre-service teachers. *Interactive Learning Environments*, 32(2), 557-571.
- Gooda, S. K., Mohanraj, P., Veni, J., Ashish, A., Kannadhasan, S., & Thamizhkani, B. (2025). Solutions for Scalable Supply chain management Systems Benefits and Implementation Strategies. In *ITM Web of Conferences* (Vol. 76, p. 05002). EDP Sciences.
- Groenewald, C. A., Groenewald, E., Uy, F., Kilag, O. K., Rabillas, A., & Cabuenas, M. H. (2024). Project agility: the role of information technology and contextual Moderators-A systematic review. *International Multidisciplinary Journal of Research for Innovation, Sustainability, and Excellence*, 1(3), 32-38.
- Hammouri, Q. M., Abu-Shanab, E. A., & Nusairat, N. M. (2021). Attitudes toward implementing E-government in health insurance administration. *International Journal of Electronic Government Research (IJEGR)*, 17(2), 1-18.

- Hammouri, Q., Nusairat, N. M., AlSokkar, A. A., Jdaitawi, A. M., Mistarihi, A. M., Akhuirshaideh, D. A. A., & AlFraihat, S. F. (2025). Engaging Gen Z through Personalized Social Media Content: The Mediating Role of Perceived Relevance on Platform Engagement.
- Hanandeh, A., Al-Badaineh, G., Kilani, Q., Freijat, S. Y., Abualfalayeh, G., & Khasawneh, M. A. (2024). The effects of social media platforms in influencing consumer behavior and improving business objectives. *International Journal of Data and Network Science*, 8(4), 2333-2340.
- Hanandeh, A., ALFreijat, S. Y., Qutieshat, R. J., Alsha'ar, H. Y., Kilani, Q. A., & Saleem Khasawneh, M. A. (2025). Implementing AI Accuracy, Learning Rate, Inference Time on enhancing Big Data Analysis and Strategic Plan. *Data and Metadata*, 4, 637.
- Hanandeh, A., Hammouri, Q., Tweijer, A. A., Kilani, Q., Abualfalayeh, G., & Khasawneh, M. A. (2024). Data-driven transformation: The influence of analytics on organizational behavior in IT service companies. *International Journal of Data and Network Science*, 8(4), 2037-2046.
- Hanandeh, A., S. Shalluf, S. Alnajdawi, O. Arafat, Q. Kilani. Hanandeh R. (2025). the Effect of Cloud-Based ERP System, Employee Competency, and Organizational Agility on Operational Efficiency and Decision-Making Quality. *Journal of Posthumanism*, 5(6), 404 - 419.
- Jakovlev, S., Eglynas, T., Jusic, M., Jankunas, V., & Voznak, M. (2025). Mitigating Container Damage and Enhancing Project Efficiency in Global Containerisation. *Sensors*, 25(7), 2019.
- Khan, T., Emon, M. M. H., & Rahman, M. A. (2024). A systematic review on exploring the influence of Industry 4.0 technologies to enhance supply chain visibility and project Efficiency. *Review of Business and Economics Studies*, 12(3), 6-27.
- MANDAVA, H. (2024). The Advantages of SCM in the Global Business Landscape. *World*, 3, 900.
- Manigandan, R., & Raghuram, J. N. V. (2024). Bridging the gap: the mediating impact of SCM adoption intention on entrepreneurial orientation and marketing performance in South Indian SMEs. *International Journal of Management and Ent SCMrise Development*, 23(1), 26-50.
- Mansour, A., Al-Qudah, S., Siam, Y., Hammouri, Q., & Hijazin, A. (2024). Employing E-HRM to attain contemporary organizational excellence at the Jordan social security corporation. *International Journal of Data and Network Science*, 8(1), 549-556.
- Masenyana, T. M., & Aroba, O. J. (2025). Factors Affecting the Implementation of SCM systems in the South African Gold Mining Industries. In *Innovation Management for a Resilient Digital Economy* (pp. 149-176). IGI Global Scientific Publishing.
- Mesioye, O., & Bakare, I. A. (2024). Evaluating financial reporting quality: Metrics, challenges, and impact on business overall performance. *Int J Res Public Rev*, 5(10), 1144-1156.
- Motwani, J., & Katatria, A. (2024). Organization agility: a literature review and research agenda. *International Journal of Productivity and Performance Management*, 73(9), 2709-2754.
- Nguyen, P. Q. P., Nguyen, D. T., Yen, N. H. T., Le, Q., Nguyen, N. T., & Pham, N. D. K. (2025). Machine Learning-Driven Insights for Optimizing Ship Fuel Consumption: Predictive Modeling and Project Efficiency. *International Journal on Advanced Science, Engineering & Information Technology*, 15(1).
- Ononiwu, M. I., Onwuzulike, O. C., & Shitu, K. (2024). The role of digital business transformation in enhancing project agility. *World Journal of Advanced Research and Reviews*, 23(3), 285-308.
- Orakova, A., Nametkulova, F., Issayeva, G., Mukhambetzhanova, S., Galimzhanova, M., & Rezuanova, G. (2024). The relationships between pedagogical and technological competence and digital literacy level of teachers. *Journal of Curriculum Studies Research*, 6(1), 1-21.
- Petchrompo, S., Chitniyom, R., Peerwantanagul, N., Laesanklang, W., Suwanapong, J., & Borrisuttanakul, S. (2025). Enhancing project Efficiency in a voluntary recycling project through data-driven waste collection optimization. *Waste Management*, 200, 114741.
- Sahin, A., Imamoglu, G., Murat, M., & Ayyildiz, E. (2024). A holistic business overall performance

- approach to assessing service quality in higher education institutions. *Socio-Economic Planning Sciences*, 92, 101812.
- Sembinging, I., Manongga, D., Rahardja, U., & Aini, Q. (2024). Understanding data-driven analytic business overall performance on air quality monitoring an empirical research. *Aptisi Transactions on Technopreneurship (ATT)*, 6(3), 418-431.
- Singh, S., Raj, R., Dash, B. M., Kumar, V., Paliwal, M., & Chauhan, S. (2024). Access to finance and its impact on project Efficiency of MSMEs: mediating role of entrepreneurial personality and self-efficacy. *Journal of Small Business and Ent SCMrise Development*.
- Smith, H. K. (2024). Impact of SCM systems on E-supply Chain Coordination and Process Synchronization.
- Syed, Z. A., Dapaah, E. M. M. A. N. U. E. L., Mapfaza, G. L. O. R. I. A., Remias, T. I. C. H. A. O. N. A., & Mupa, M. N. (2024). Enhancing supply chain resilience with SCM systems'. *IRE Journals*, 8(2), 106-128.
- Tian, X., Zhu, J., Zhao, X., & Wu, J. (2024). Improving project Efficiency through blockchain: evidence from a field experiment in cross-border trade. *Production Planning & Control*, 35(9), 1009-1024.
- Virmani, N., Upadhyay, M., Luthra, S., Singh, S., & Upadhyay, A. (2024). Assessing solutions to overcome Quality 4.0 barriers: a business overall performance framework. *The TQM Journal*, 36(6), 1460-1485.